

Weld on with hull in place to ensure the gap between hull and post is even and sufficient at the top

6mm alignment hole in drawbar

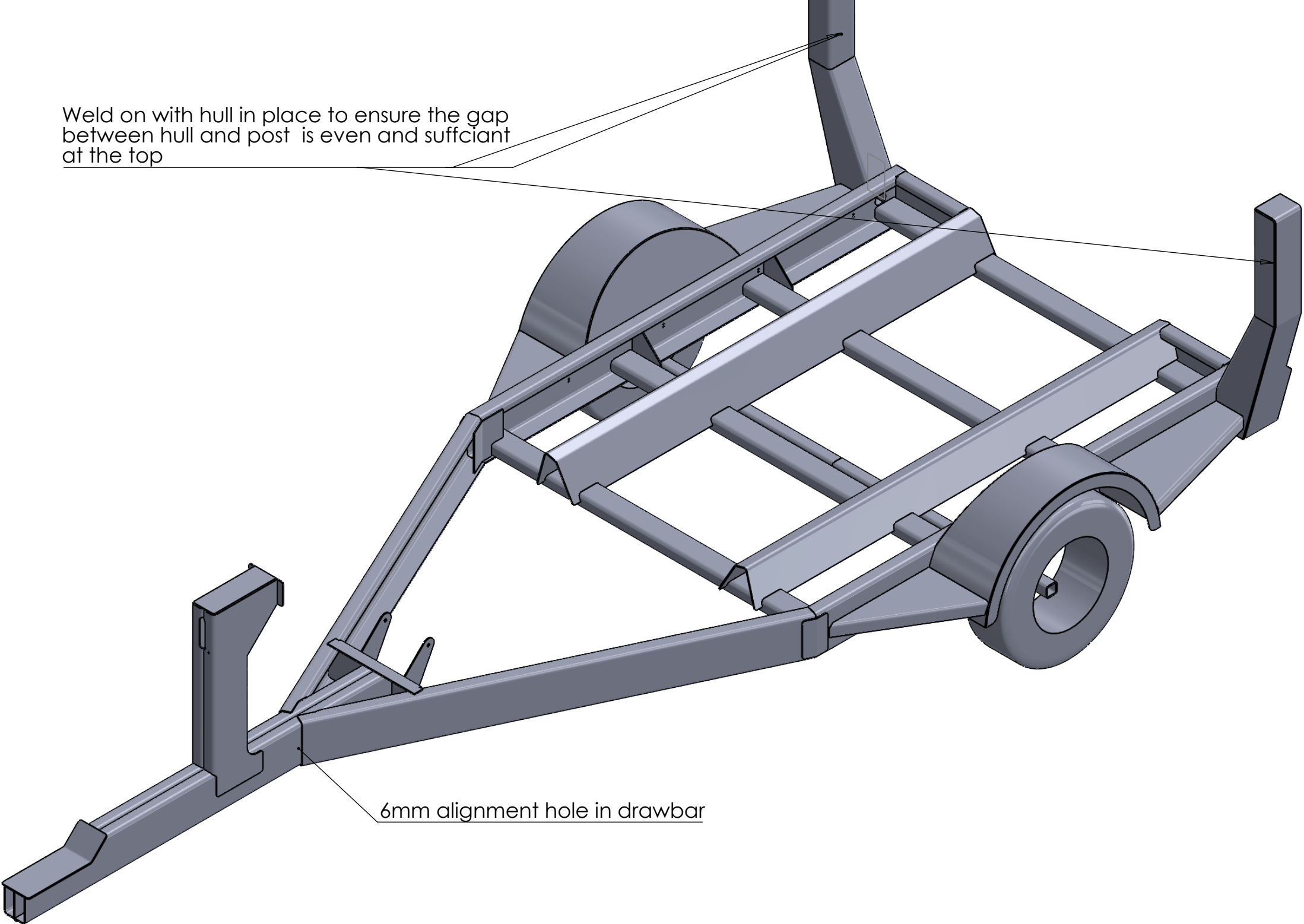

Weld winch post on with hull in place to get position right

Weld on with hull and roller in place to get position right

Gusset plate

UHMWPE blocks to  
bunks, cross mebers in  
center and side posts

